

**morosini /
evistyle**

**news
2015**

/index

MOROSINI®
luce & design

CUEVA 02

DICE 46

MIKADO 22

SANTRAL 10

SUNRISE ECO 38

EviStyle®
Passion for light

MEMORIA 70

VINTAGE 52







CUEVA SO 20

MOROSINI



DESIGN FILIPPO MAMBRETTI

CUEVA SO 40

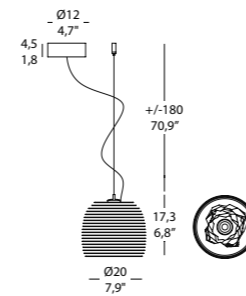
**CUEVA SO 20**

9,3W 975 Lm 3000K Cri>80 220-240V LED

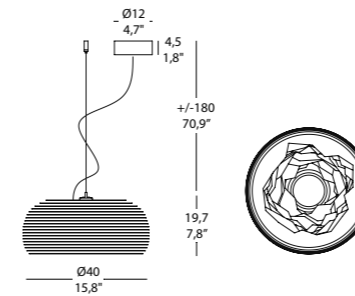
**CUEVA SO 40**

7,5W 930 Lm 3000K Cri>80 220-240V LED

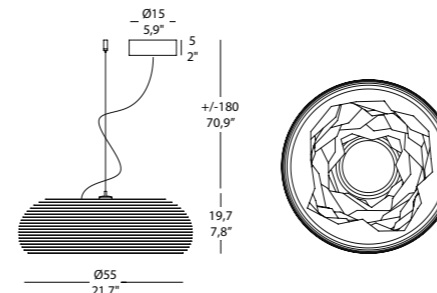
**CUEVA SO 55**

23,1W 2830 Lm 3000K Cri>80 220-240V LED

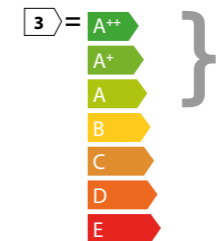

Cueva è una collezione di lampade a sospensione dal design essenziale quanto ricercato, la prova che si può ottenere pulizia formale anche nella complessità. L'illuminazione prodotta da sorgenti LED, a contatto con fogli di alluminio minuziosamente sovrapposti, arricchisce di ammalianti chiaroscuri le composizioni geometriche racchiuse all'interno della lampada, e filtrando all'esterno assicura un design sobrio ed essenziale. Da qualunque prospettiva la si guardi, Cueva è pura poesia estetica.

Struttura: metallo bianco opaco.
Diffusore: policarbonato opalino.

Cueva is a collection of pendant lamps with an essential but at the same time sophisticated design, proof that you can get clean lines also in complexity. The light produced by LED sources and the carefully overlapping aluminium foils enrich the geometric compositions inside the lamp with a fascinating chiaroscuro, and, filtering from the outside, the light ensures a simple and essential design. From whatever perspective you look at it from, Cueva is pure aesthetic poetry.

Frame: matt white metal
Diffuser: opal polycarbonate.

Cueva est une collection de lampes à suspension au design aussi essentiel que raffiné, prouvant que l'on peut également obtenir une netteté formelle dans la complexité. L'éclairage produit par les sources LED, au contact de feuilles d'aluminium minutieusement superposées, enrichit les compositions géométriques contenues dans la lampe de clairs-obscur envoûtants, et il assure, en filtrant à l'extérieur, un design sobre et essentiel. Dans toute perspective, Cueva est une pure poésie esthétique.

Structure: métal blanc mat
Diffuseur: polycarbonate opalin.

Cueva ist eine Lampenkollektion mit Abhängung und gewollt einfachem Design. Der Beweis dafür, dass klare Linien auch in der Komplexität entstehen können. Die Ausleuchtung die durch die LED-Lichtquellen erzeugt werden, die wiederum im Kontakt mit den präzise übereinander gelegten Aluminiumstreifen stehen, bereichert mit bezaubernden Hell-Dunkel Kontrasten die geometrischen Kompositionen die im Inneren der Lampe eingeschlossen sind und aussen filtrieren. Ein essenzielles und

CUEVA

technical detailed lists

design **filippo mambretti**

schlichtes Design.
Aus welcher Perspektive man sie auch betrachtet, Cueva ist reine und ästhetische Poesie.

Struktur: Metall mattweiß.
Diffusor: Polycarbonat opalartig Weiß.

Cueva es una colección de lámparas de suspensión de design esencial y rebuscado, la prueba de que se puede obtener esencialidad formal también en la complejidad.

La iluminación producida por fuentes LED, en contacto con hojas de aluminio minuciosamente sobrepuestas, enriquece de cautivantes claroscuros las composiciones geométricas encerradas en el interior de la lámpara y filtrando en el exterior asegura un design sobrio y esencial. Desde cualquier perspectiva se vea, Cueva es pura poesía estética.

Estructura: metal blanco opaco.
Difusor: policarbonato opalescente.

Cueva – коллекция подвесных светильников простого и в то же время изысканного дизайна, подтверждение того, что возможно добиться определенной чистоты даже в сложности.

Свет, полученный при помощи источников LED, в контакте с алюминиевыми листами, наложенными друг на друга, обогащает завораживающей игрой светотеней геометрические композиции, заключенные внутри светильника, и, фильтруя с внешней стороны, обеспечивает простой и строгий дизайн.

Cueva - это чистая изящная поэзия, с какой бы стороны на нее не посмотреть.

Структура: белый матовый металл
Рассеиватель: Поликарбонат опалового цвета.

santral

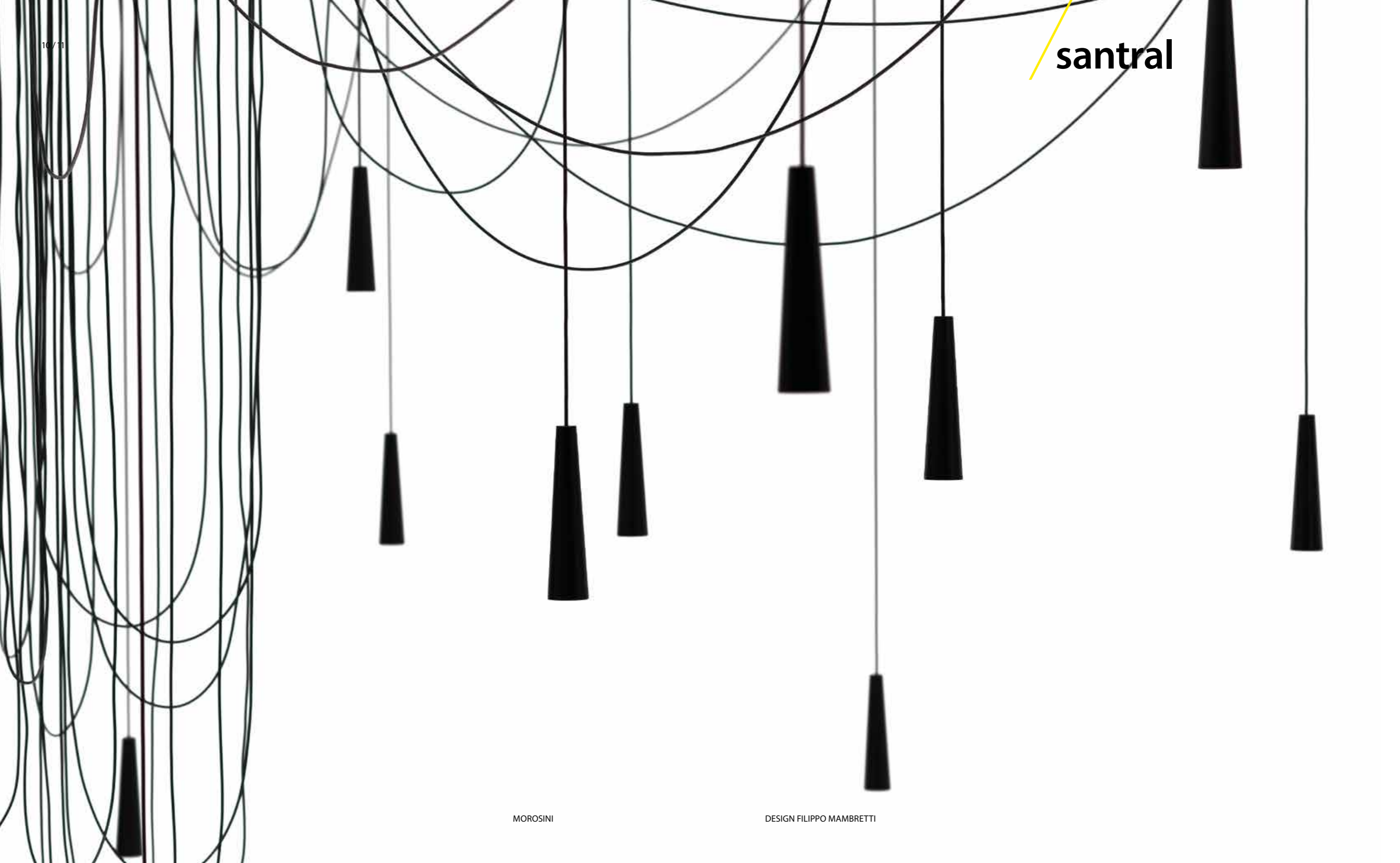





SANTRAL esempio di composizione 16 luci/16 lights composition example

MOROSINI



DESIGN FILIPPO MAMBRETTI

SANTRAL esempio di composizione 8 luci/8 lights composition example

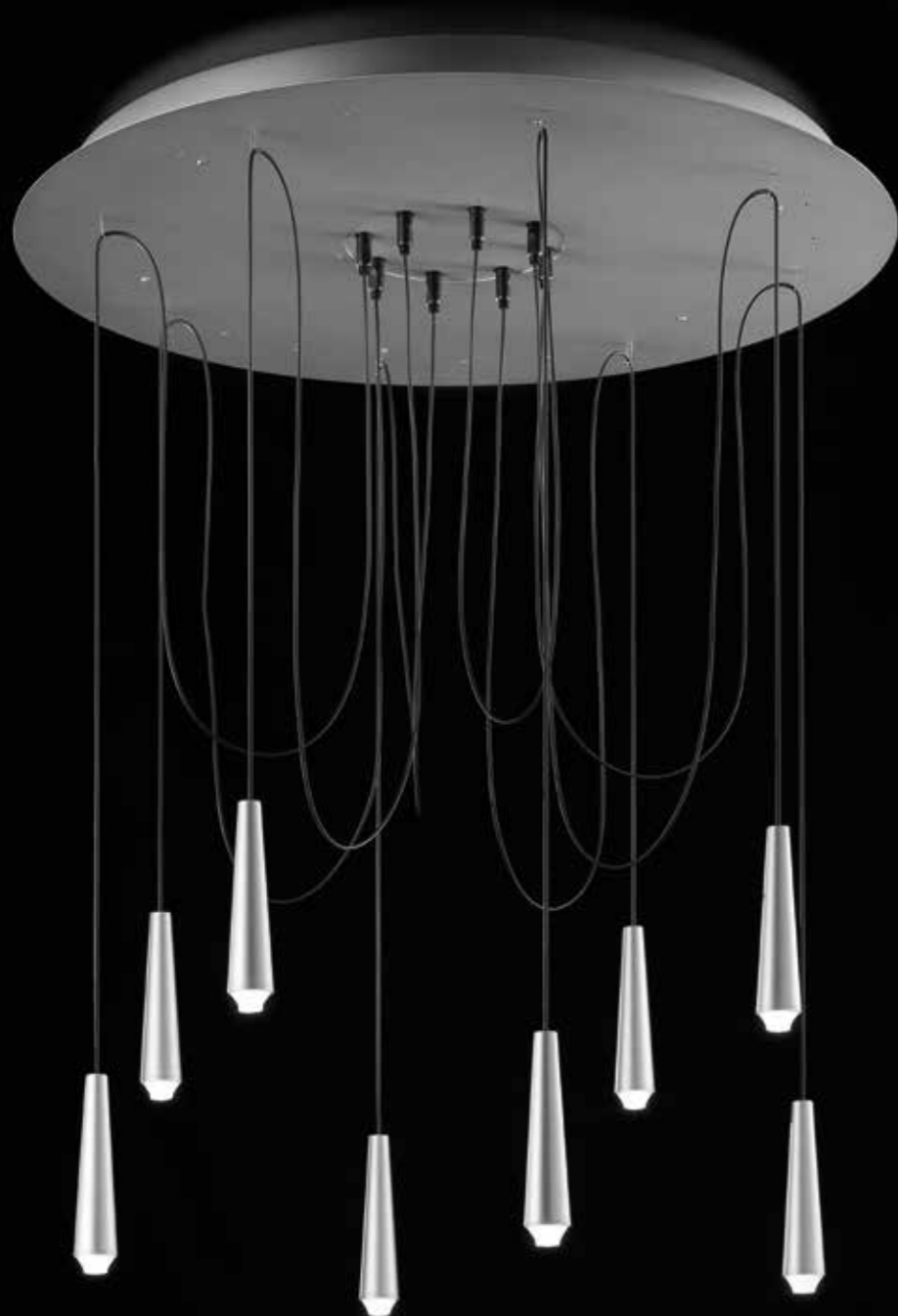

SANTRAL esempio di composizione 8 luci/8 lights composition example

MOROSINI



DESIGN FILIPPO MAMBRETTI

SANTRAL esempio di composizione 16 luci/16 lights composition example



SANTRAL esempio di composizione 24 luci/24 lights composition example

MOROSINI



DESIGN FILIPPO MAMBRETTI

CAVI DI SERIE/STANDARD CABLES

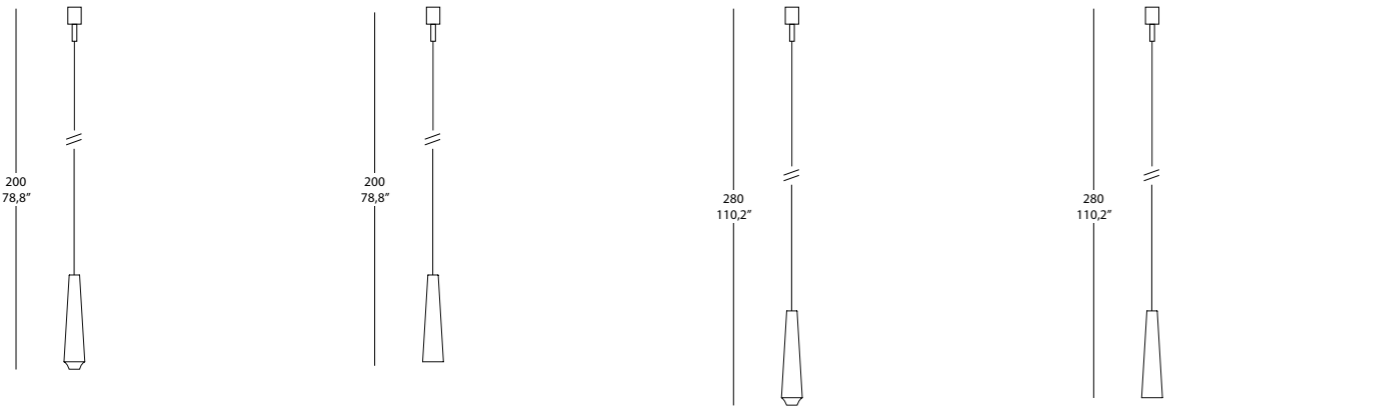
**SANTRAL 200 GLASS**

3,1W 325 Lm 3000K Cri>80 350 mA LED

**SANTRAL 200**

3,1W 325 Lm 3000K Cri>80 350 mA LED

**SANTRAL 280 GLASS**

3,1W 325 Lm 3000K Cri>80 350 mA LED

**SANTRAL 280**

3,1W 325 Lm 3000K Cri>80 350 mA LED

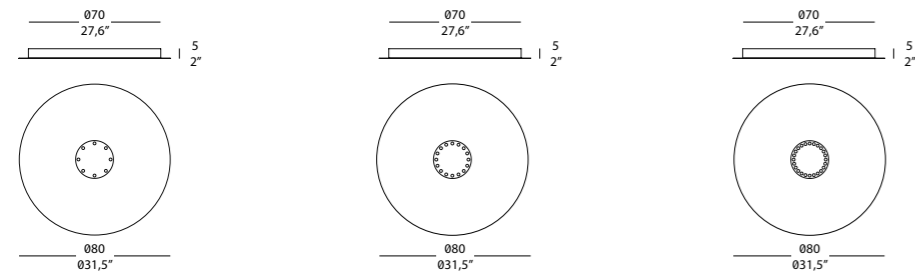

ROSONI/CANOPIES

**SANTRAL R08**ROSONE A 8 LUCI CON DRIVER 220-240V
8-LIGHT CANOPY WITH DRIVER 220-240V**SANTRAL R016**ROSONE A 16 LUCI CON DRIVER 220-240V
16-LIGHT CANOPY WITH DRIVER 220-240V**SANTRAL R024**ROSONE A 24 LUCI CON DRIVER 220-240V
24-LIGHT CANOPY WITH DRIVER 220-240V

ESEMPLI DI COMPOSIZIONE/ EXAMPLES OF COMPOSITION

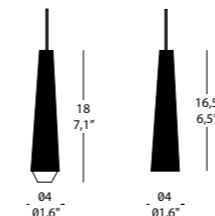
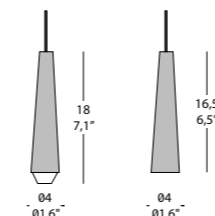
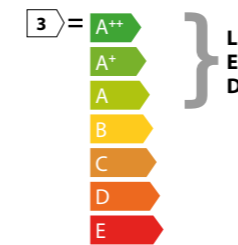
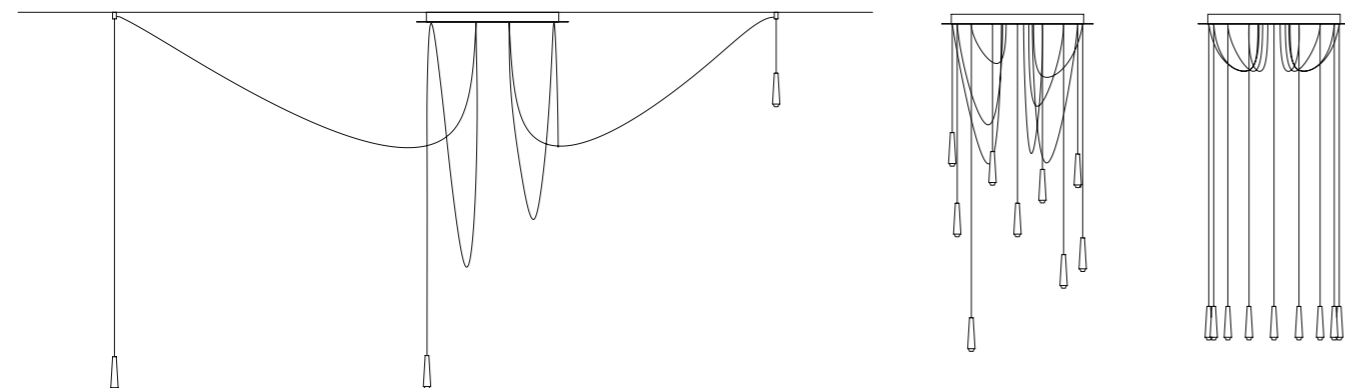

JACK SYSTEM



Santral rivoluziona l'estetica classica dei lampadari a sospensione. La collezione è altamente personalizzabile nel design grazie ai cavi indipendenti con i quali è possibile creare infinite composizioni sia all'interno dello spazio circoscritto del rosone, sia liberamente all'esterno per mezzo di ancoraggi fissati al soffitto. Si ottiene così un oggetto d'arredo capace di caratterizzare con formalità e assoluta originalità sia location circoscritte che ambienti spaziosi. Di facile installazione grazie ad un sistema di jack, Santral prevede sorgenti a LED racchiuse in particolari metallici di forma conica, disponibili anche con diffusore in vetro soffiato satinato che impreziosisce ulteriormente la collezione.

Struttura: metallo nero opaco o grigio alluminio.
Diffusore: vetro satinato.

Santral revolutionizes the classic aesthetics of pendant chandeliers. The collection is highly customizable in design thanks to independent cables with which you can create endless compositions within the ceiling rose of the lamp, but also outside of it, through anchors that are fixed to the ceiling. The result is a piece of furniture able to give formality and absolute originality to small locations but also to big spaces. Thanks to a system of jacks, Santral is easy to be installed and provides LED sources which are inside of conical metallic elements, also available with a diffuser in blown glass that further enhances the collection.

Frame: matt black metal or aluminium-grey.
Diffuser: satin glass

Santral bouleverse l'esthétique classique des lustres à suspension. La collection est hautement personnalisable au niveau du design grâce aux câbles indépendants avec lesquels on peut créer d'infinies compositions à l'intérieur de l'espace

circoscrit de la plaque ronde, et librement à l'extérieur au moyen d'ancrages fixés au plafond. On obtient ainsi un objet de décoration capable de caractériser avec une formalité et une originalité absolue des espaces circonscrits et des pièces spacieuses. Facile à installer grâce à un système de jacks, Santral prévoit des sources à LED contenues dans des éléments métalliques de forme conique, également fournis avec un diffuseur en verre soufflé satiné qui enrichit ultérieurement la collection.

Structure: métal noir mat ou gris aluminium.
Diffusor: verre satiné.

Santral revolucioniza la estética clásica de las arañas. La colección es perfectamente personalizable en el design gracias a los cables independientes con los cuales es posible crear infinitas composiciones tanto en el interior del espacio circunscrito del rosetón como libremente en el exterior por medio de anclajes fijados al techo. Se obtiene así un objeto de decoración en condiciones de caracterizar con formalidad y absoluta originalidad tanto lugares circunscritos como ambientes espaciosos. De fácil instalación gracias a un sistema de jack, Santral prevé fuentes de LED encerradas en detalles metálicos de forma cónica, disponibles incluso con difusor de vidrio soplado satinado que valoriza ulteriormente la colección.

Estructura: metal negro opaco o gris aluminio.
Difusor: vidrio satinado.

Santral revolutioniert die klassische Ästhetik der Hängelampen. Die Kollektion ist durch unabhängige Kabel vielseitig im Design personalisierbar. Mit diesen kann man unzählige Kompositionen erstellen, im engen Inneren der Rosette, aber auch bequem aussen durch

DECENTRAMENTO/ OFF CENTRE POSITION



SANTRAL

technical
detailed listsdesign **filippo mambretti**

Deckenbefestigungen Dadurch entsteht ein Einrichtungsgegenstand, der durch seine Formalität und absolute Originalität in engen Räumen, wie auch geräumigen Umgebungen besticht. Mit einem einfachen Buchsen-Montagesystem ausgestattet, sieht Santral LED-Lichtquellen vor, die in metallische Teile mit konischer Form eingeschlossen sind. Erhältlich auch mit Diffusor aus satiniertem und geblasenem Glas, das die Kollektion nochmals erheblich aufwertet.

Struktur: Metall, mattschwarz oder Graualuminium.
Diffusor: Satiniertes Glas.

Santral производит коренной переворот в классической эстетике подвесных светильников. Коллекция обладает большими возможностями персонализации дизайна, благодаря отдельным проводам, с помощью которых возможно создать бесконечное множество композиций, как внутри пространства, ограниченного потолочной чашей, так и снаружи с помощью потолочных анкеров. Таким образом, создается предмет обстановки, способный охарактеризовать формально и с абсолютной оригинальностью как ограниченные пространства, так и просторные помещения. Легко монтируется благодаря системе jack, Santral предусматривает источники света LED, заключенные в металлические элементы конической формы, которые также могут быть предложены с рассеивателем из дутого сатинированного стекла, придающего коллекции дополнительную ценность.

Структура: металл, выполняется в цвете: черный матовый или серый алюминий.
Рассеиватель: Сатинированное стекло

 mikado





MIKADO LA 6

MOROSINI

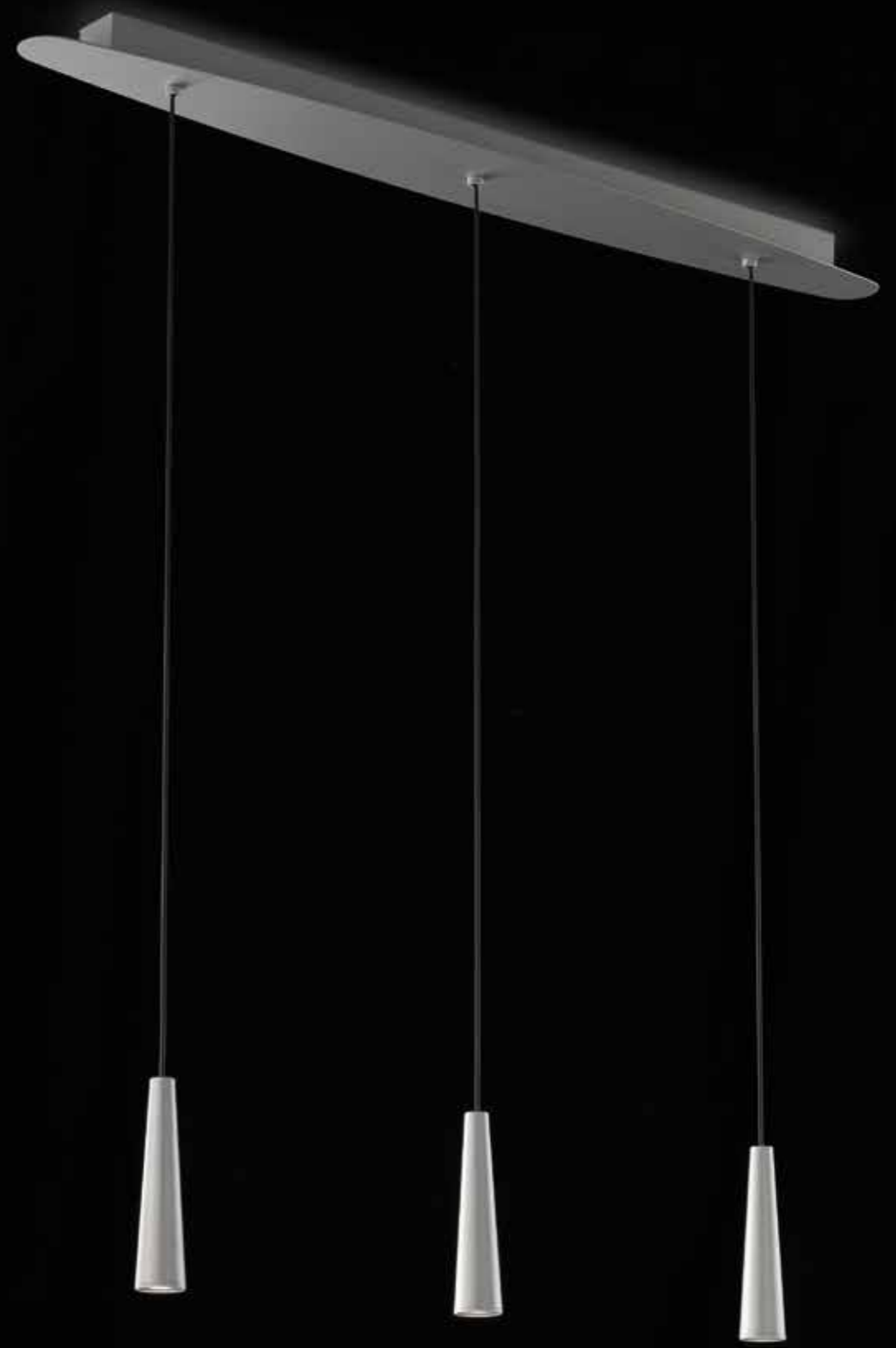

DESIGN FILIPPO MAMBRETTI

MIKADO S3L

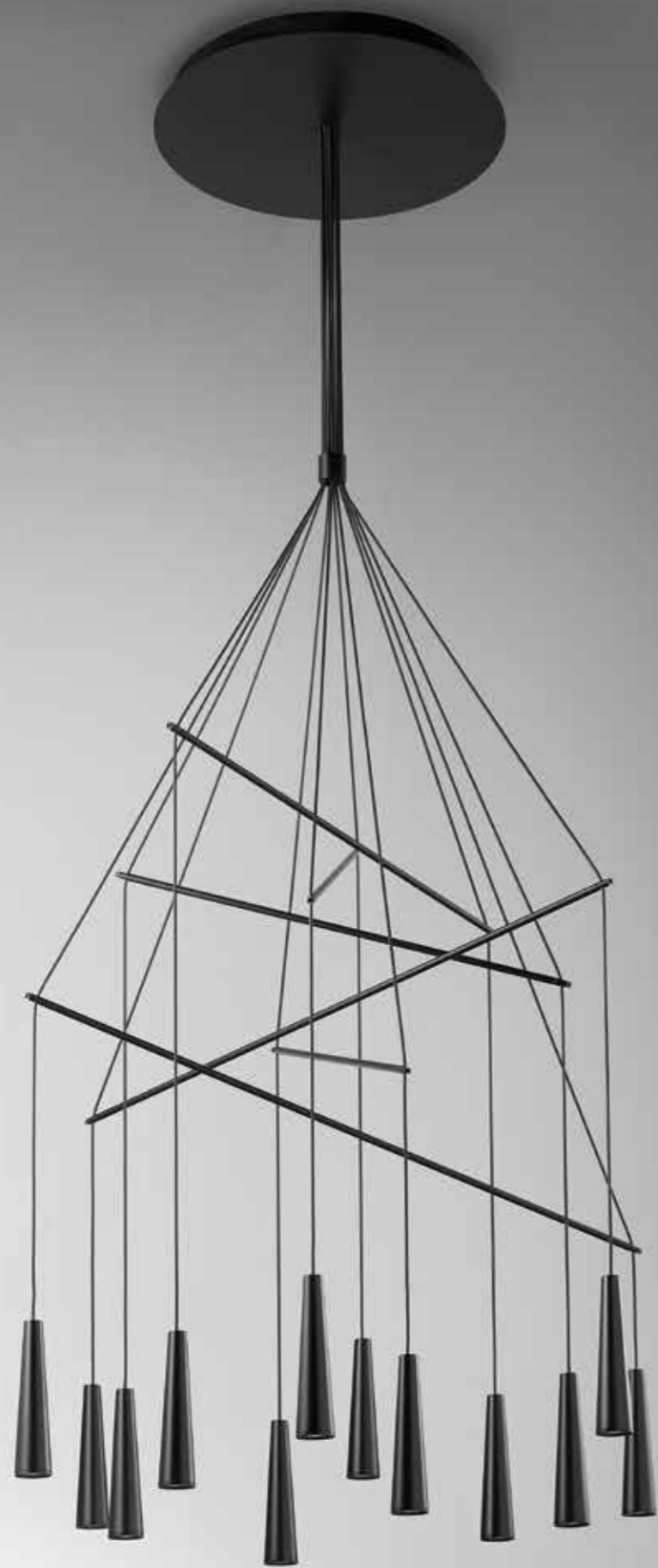

MIKADO LA 12

MOROSINI



DESIGN FILIPPO MAMBRETTI

MIKADO S5L GLASS



MOROSINI

IN FILIPPO MAMBRETTI

MIKADO SO 1 GLASS



MIKADO LA 12 GLASS

MOROSINI



DESIGN FILIPPO MAMBRETTI

MIKADO S2L GLASS



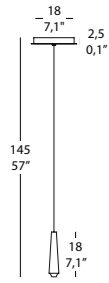

MIKADO SO 1 GLASS_S
1x3,1W 325 Lm 3000K Cri>80 220-240V LED
CE F IP 20 3

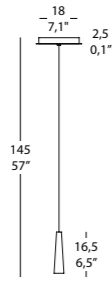

MIKADO SO 1_S
1x3,1W 325 Lm 3000K Cri>80 220-240V LED
CE F IP 20 3

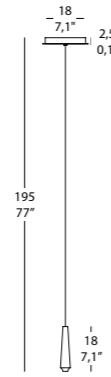

MIKADO SO 1 GLASS_L
1x3,1W 325 Lm 3000K Cri>80 220-240V LED
CE F IP 20 3

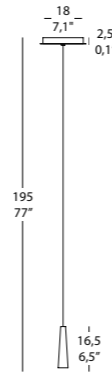

MIKADO SO 1_L
1x3,1W 325 Lm 3000K Cri>80 220-240V LED
CE F IP 20 3

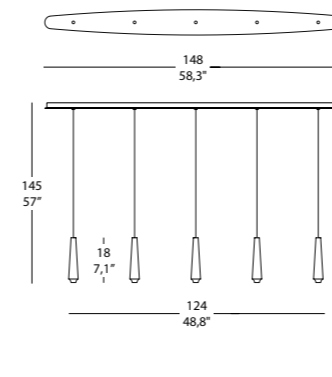

MIKADO SSL GLASS_S
5x3,1W 1625 Lm 3000K Cri>80 220-240V LED
CE F IP 20 3

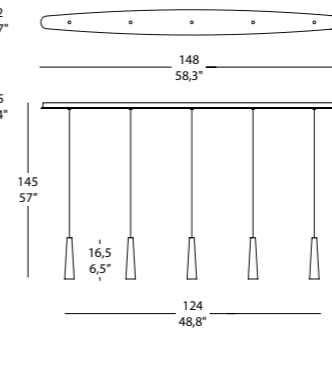

MIKADO SSL_S
5x3,1W 1625 Lm 3000K Cri>80 220-240V LED
CE F IP 20 3

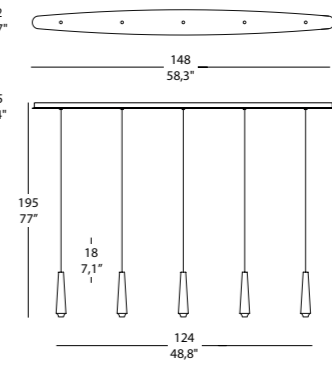

MIKADO SSL GLASS_L
5x3,1W 1625 Lm 3000K Cri>80 220-240V LED
CE F IP 20 3

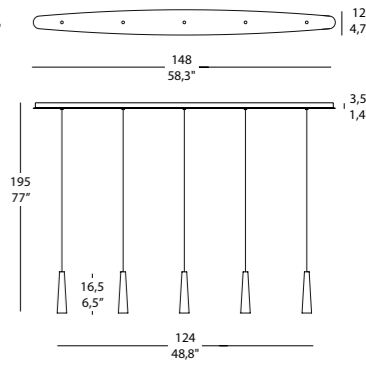

MIKADO SSL_L
5x3,1W 1625 Lm 3000K Cri>80 220-240V LED
CE F IP 20 3

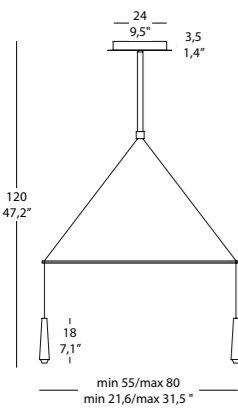

MIKADO S2L GLASS_S
2x3,1W 650 Lm 3000K Cri>80 220-240V LED
CE F IP 20 3

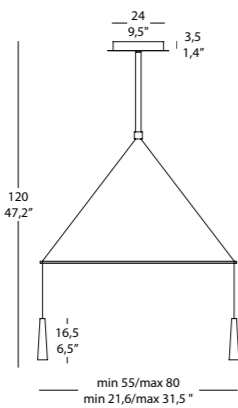

MIKADO S2L_S
2x3,1W 650 Lm 3000K Cri>80 220-240V LED
CE F IP 20 3

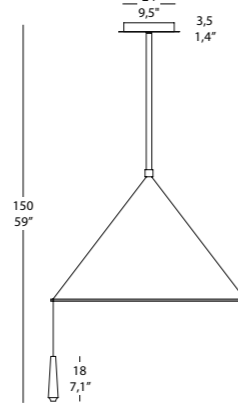

MIKADO S2L GLASS_L
2x3,1W 650 Lm 3000K Cri>80 220-240V LED
CE F IP 20 3

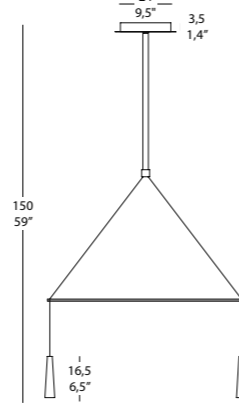

MIKADO S2L_L
2x3,1W 650 Lm 3000K Cri>80 220-240V LED
CE F IP 20 3

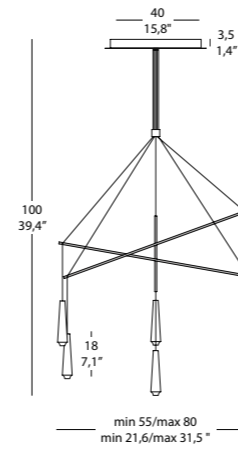

MIKADO LA 6 GLASS_S
6x3,1W 1950 Lm 3000K Cri>80 220-240V LED
CE F IP 20 3

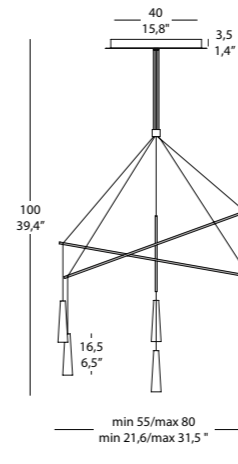

MIKADO LA 6_S
6x3,1W 1950 Lm 3000K Cri>80 220-240V LED
CE F IP 20 3

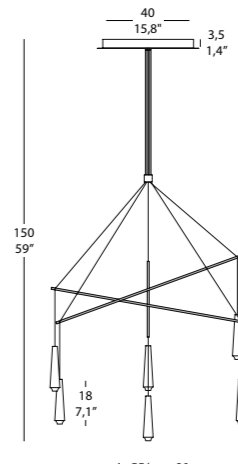

MIKADO LA 6 GLASS_L
6x3,1W 1950 Lm 3000K Cri>80 220-240V LED
CE F IP 20 3

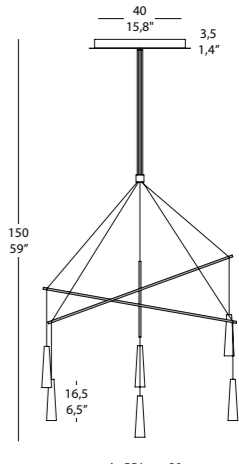

MIKADO LA 6_L
6x3,1W 1950 Lm 3000K Cri>80 220-240V LED
CE F IP 20 3

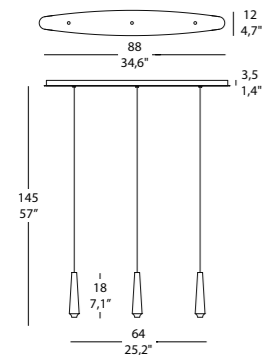

MIKADO S3L GLASS_S
3x3,1W 915 Lm 3000K Cri>80 220-240V LED
CE F IP 20 3

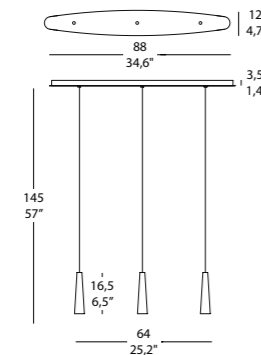

MIKADO S3L_S
3x3,1W 915 Lm 3000K Cri>80 220-240V LED
CE F IP 20 3

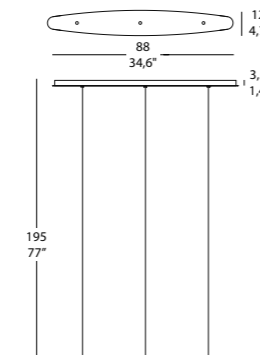

MIKADO S3L GLASS_L
3x3,1W 915 Lm 3000K Cri>80 220-240V LED
CE F IP 20 3

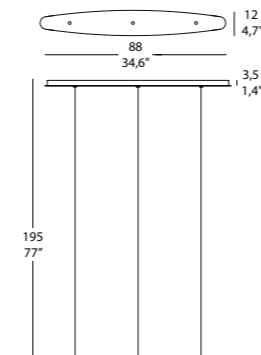

MIKADO S3L_L
3x3,1W 915 Lm 3000K Cri>80 220-240V LED
CE F IP 20 3

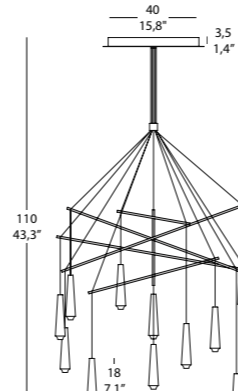

MIKADO LA 12 GLASS_S
12x3,1W 3900 Lm 3000K Cri>80 220-240V LED
CE F IP 20 3

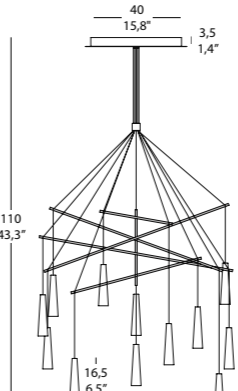

MIKADO LA 12_S
12x3,1W 3900 Lm 3000K Cri>80 220-240V LED
CE F IP 20 3

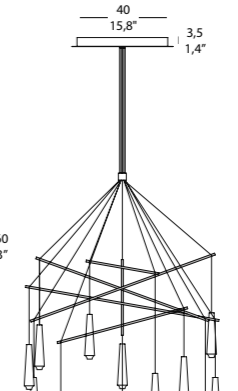

MIKADO LA 12 GLASS_L
12x3,1W 3900 Lm 3000K Cri>80 220-240V LED
CE F IP 20 3

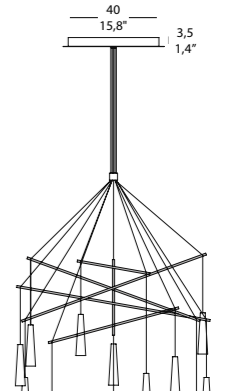

MIKADO LA 12_L
12x3,1W 3900 Lm 3000K Cri>80 220-240V LED
CE F IP 20 3

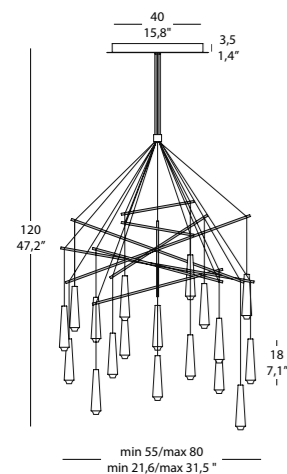
**MIKADO LA 18 GLASS_S**

18x3,1W 5850 Lm 3000K Cri>80 220-240V LED

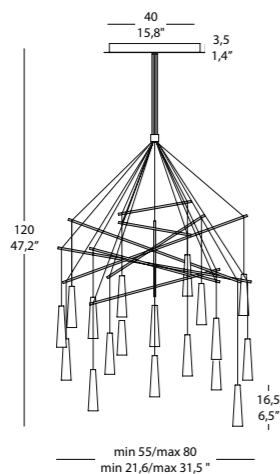
**MIKADO LA 18_S**

18x3,1W 5850 Lm 3000K Cri>80 220-240V LED

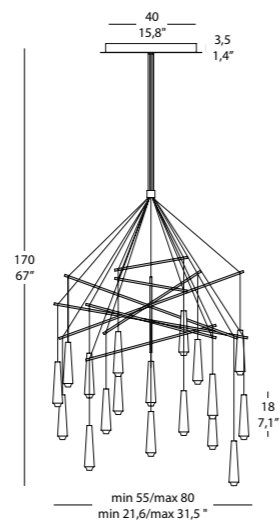
**MIKADO LA 18 GLASS_L**

18x3,1W 5850 Lm 3000K Cri>80 220-240V LED

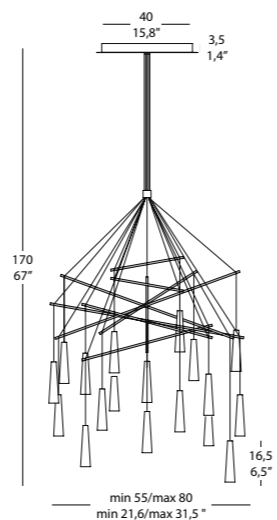
**MIKADO LA 18_L**

18x3,1W 5850 Lm 3000K Cri>80 220-240V LED

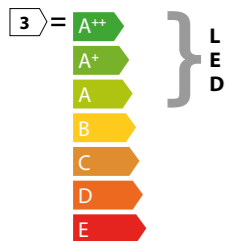
**BARRA/BAR 50**

GRIGIO ALLUMINIO/ALUMINUM GREY

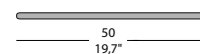
**BARRA/BAR 50**

NERO ALLUMINIO/ALUMINUM BLACK

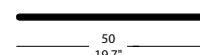
**BARRA/BAR 75**

GRIGIO ALLUMINIO/ALUMINUM GREY

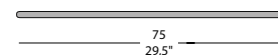
**BARRA/BAR 75**

NERO ALLUMINIO/ALUMINUM BLACK

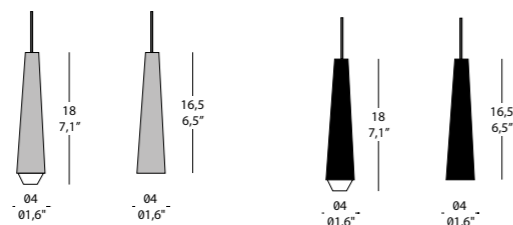
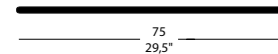

Rilettura in chiave destrutturata dell'estetica classica dei lampadari a sospensione. Mikado è un intreccio di linee e piani che producono un fluttuante movimento nello spazio generando figure geometriche semplici o complesse. Le varie versioni a sospensione, lineari o circolari, permettono diversi gradi di personalizzazione ed elaborazione della struttura: sobria e minimalista o complessa ed eccentrica grazie alla sovrapposizione di piani ad altezze asimmetriche. Le sorgenti a LED sono racchiuse in particolari metallici di forma conica, disponibili anche con diffusore in vetro soffiato satinato che impreziosisce ulteriormente la collezione.

Struttura: metallo nero opaco o grigio alluminio.

Diffusore: vetro satinato.

A deconstructive reinterpretation of the classical aesthetics of pendant chandeliers. Mikado is a mixture of lines and planes that produce a fluctuating movement in space creating simple or complex geometric figures.

The various linear or circular pendant versions allow different degrees of customization and elaboration of the frame: simple and minimalist or complex and eccentric thanks to the overlapping planes at asymmetric heights. The LED sources are enclosed inside of conical metallic elements, available also with satin blown glass diffuser, further enriching the collection.

Frame: matt black metal or aluminium-grey.

Diffuser: satin glass

Relecture sous un jour déstructuré de l'esthétique classique des lustres à suspension. Mikado est un enchevêtrement de lignes et de plans qui produisent un mouvement fluctuant dans l'espace générant des figures géométriques simples ou complexes. Les différentes versions à suspension, linéaires ou circulaires, permettent différents degrés de personnalisation et d'élaboration de la structure: sobre et minimaliste ou complexe et excentrique grâce à la superposition de plans à des hauteurs asymétriques.

Les sources à LED sont contenues dans des éléments métalliques de forme conique, également fournis avec un diffuseur en verre soufflé satiné qui enrichit ultérieurement la collection.

Structure: métal noir mat ou gris aluminium.

Diffuseur: verre satiné.

Relectura en clave descompuesta de la estética clásica de las lucernas suspendidas, Mikado es un enredo de líneas y planos que producen un movimiento oscilante en el espacio generando figuras geométricas simples y complejas. Las varias versiones a suspensión, lineales o circulares, permiten varios grados de personalización y elaboración de la estructura: sobria y minimalista o compleja y excéntrica gracias a la superposición de planos de alturas asimétricas.

Las fuentes de LED están encerradas en detalles metálicos de forma cónica, disponibles incluso con difusor de vidrio soplado satinado que valoriza ulteriormente la colección.

Estructura: metal negro opaco o gris aluminio.

Difusor: vidrio satinado.

Eine unstrukturierte Neuinterpretation der klassischen Ästhetik von Hängelampen. Mikado ist ein Geflecht aus Linien und Ebenen das schwankende Bewegungen im Raum produziert, indem es einfache und komplexe Geometrie-Figuren erzeugt. Die verschiedenen Ausführungen der Abhängungen, linear oder kreisförmig, ermöglichen diverse Möglichkeiten der Personalisierung und Ausarbeitung der Struktur: schlicht und minimalistisch, oder komplex und exzentrisch, dank der Überlappung der Ebenen in asymmetrischen Abständen. Die LED-Lichtquellen sind eingeschlossen in metallische Teile mit konischer Form. Erhältlich auch mit Diffusor aus satiniertem und geblasenen Glas, das die Kollektion nochmals erheblich aufwertet.

Struktur: Metall, mattschwarz oder Graualuminium.

Diffusor: Satiniertes Glas.

Новая интерпретация в деструктивном ключе классической эстетики подвесных светильников. Mikado – это переплетение линий и плоскостей, которые вызывает колышущееся движение в пространстве, создавая простые и сложные геометрические фигуры. Разнообразные версии подвесного

MIKADO

technical detailed lists

design **filippo mambretti**

светильника, как с линейным, так и с круговым расположением, позволяют разную степень персонализации и отделки структуры: строгую и минималистичную или, благодаря ассиметричному расположению плоскостей по высоте, сложную и эксцентричную. Источники LED заключены в металлические элементы конической формы, которые также могут быть предложены с рассеивателем из дутого сатинированного стекла, придающего коллекции дополнительную ценность.

Структура: металл, выполняется в цвете: черный матовый или серый алюминий.

Рассеиватель: Сатинированное стекло

sunrise eco





SUNRISE ECO PA510 E

MOROSINI



DESIGN UFFICIO STILE



SUNRISE ECO PA270 E



SUNRISE ECO PA390 LED

MOROSINI



DESIGN UFFICIO STILE

SUNRISE ECO PA50 G9

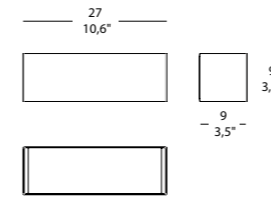
**SUNRISE ECO PA270 E**

1 x MAX 26W G24q3

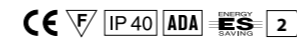
**E:** ballast elettronico/
electronic ballast**SUNRISE ECO PA270 LED**

12,4W 1640Lm 3000K Cri>80 220-240V

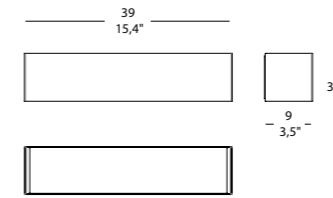
**SUNRISE ECO PA390 E**

2 x MAX 18W G24q2

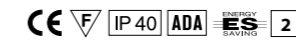
**E:** ballast elettronico/
electronic ballast**SUNRISE ECO PA390 LED**

22,8W 3000Lm 3000K Cri>80 220-240V

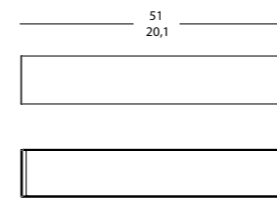
**SUNRISE ECO PA510 E**

2 x MAX 26W G24q3

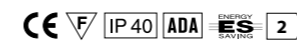
**E:** ballast elettronico/
electronic ballast**SUNRISE ECO PA510 LED**

37,2W 4920Lm 3000K Cri>80 220-240V

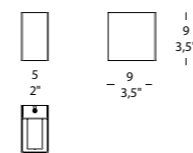
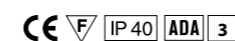
**SUNRISE ECO PA50 G9**

1 x MAX 42-53W G9 alo.

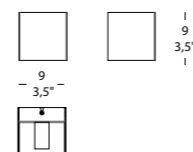
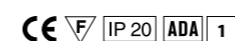
**SUNRISE ECO PA90 G9**

1 x MAX 42-53W G9 alo.

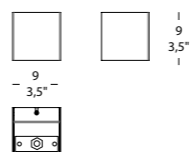
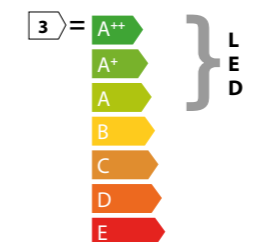
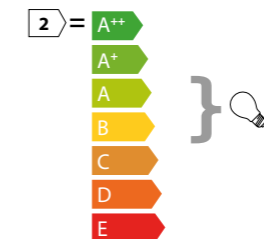
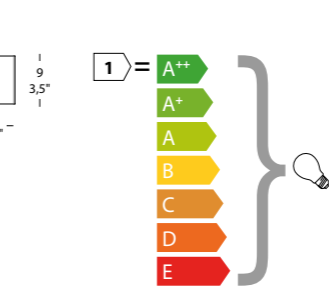
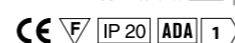
**SUNRISE ECO PA90 LED**

8,4W 1035Lm 3000K Cri>80 220-240V

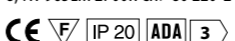
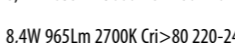

SUNRISE ECO

technical
detailed listsdesign **Ufficio Stile**

Una lampada dal design essenziale, minimale, discreto come il primo sole che sorge all'orizzonte. Frutto di un restyling che ne ha ulteriormente raffinato l'aspetto, mettendo in luce nello stesso tempo tutta la sapienza tecnica di Morosini, oltre che la sua attenzione per l'ambiente. Sunrise Eco è infatti disponibile anche a LED. Una soluzione brillante, quanto ecocompatibile.

Struttura: acciaio inox satinato o bianco opaco o nero opaco.
Diffusore: vetro satinato.

A lamp with an essential, minimalist and moderate design as the first sunrise on the horizon. It is the result of a restyling that has further improved the look of the lamp, highlighting at the same time all the Morosini know how, as well as the attention to the environment. Sunrise Eco is also available in LED. A solution as brilliant as eco-friendly.

Frame: satin finish stainless steel or matt white or matt black.
Diffuser: satin glass.

Une lampe design et essentielle, minimale, discret comme le soleil qui se lève à l'horizon. Fruit d'un restyling qui en a ultérieurement raffiné l'aspect, en dévoilant en même temps tout le savoir technique de Morosini, ainsi que l'attention qu'elle porte à l'environnement. Sunrise Eco est en effet également disponible dans la version à LED. Une solution brillante et écologique.

Structure: acier inox satiné ou blanc mat ou noir mat.
Diffuseur: verre satiné

Una lámpara de design esencial, minimal, discreto como el primer sol que surge en el horizonte. Fruto de un restyling que ha refinado ulteriormente el aspecto, poniendo en luz al mismo tiempo toda la sabiduría técnica de Morosini, además que su atención al ambiente. Sunrise Eco está en efecto disponible también en versión LED. Una solución brillante y ecocompatible.

Estructura: acero inox satinado o blanco opaco o negro opaco.
Difusor: vidrio satinado.

Eine Lampe mit einem essentiellen, minimalen Design, diskret wie der erste Sonnenstrahl am Horizont. Ergebnis eines Restylings das seinen Aspekt noch verfeinert hat und gleichzeitig das ganze technische Wissen und auch das Umweltbewusstsein von Morosini ans Licht gebracht hat. Sunrise Eco ist auch in der LED-Ausführung erhältlich. Eine brillante und umweltbewusste Lösung. Erhältlich auch in der Version mit LED.

Struktur: Satiniertes Edelstahl, oder mattweiß, oder mattschwarz.
Diffusoren: Satiniertes Glas.

Светильник сдержанного дизайна, простого и минималистического, как первые лучи солнца, поднимающегося над горизонтом. Результат модернизации, полностью изменивший его внешний вид, показав, наряду с бережным отношением к внешней среде, все технические знания MOROSINI.

Модель Sunrise Eco доступна также в версии LED. Это превосходное, эко-совместимое решение.

Структура: нержавеющей сатинованная сталь или белый матовый цвет или черный матовый цвет.
Рассеиватель: сатинованное стекло.



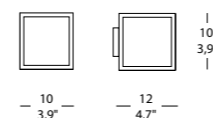
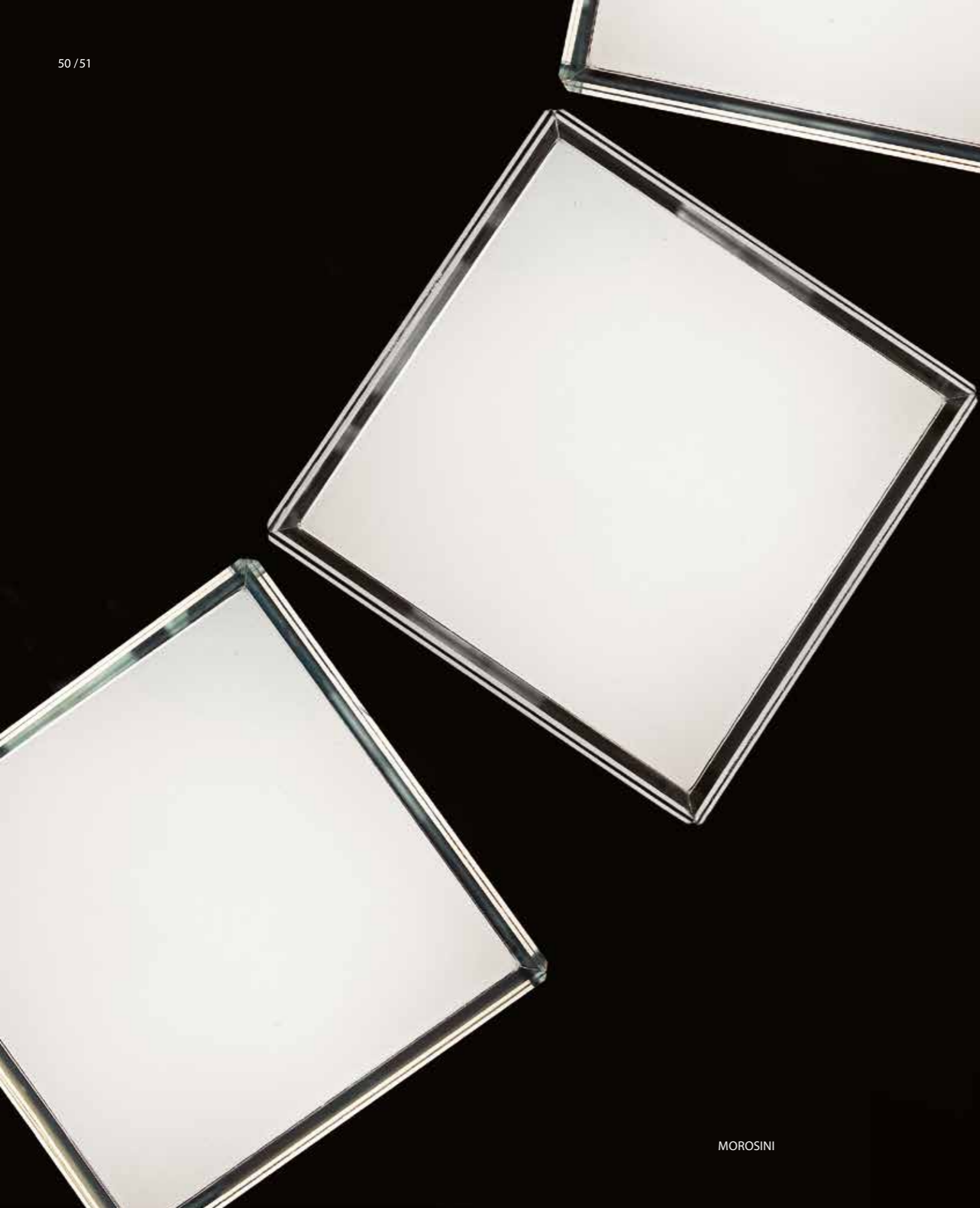

**DICE PP 10**

1 x MAX 42/53W G9 alo. ENERGY SAVER

o/or

1 x MAX 9W G9 halopin ENERGY SAVER

CE IP40 1

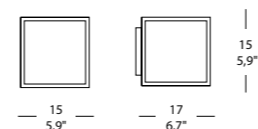
**DICE PP 15**

1 x MAX 70W E27 alo. ENERGY SAVER

o/or

1 x MAX 15W E27 ENERGY SAVER

CE IP40 1

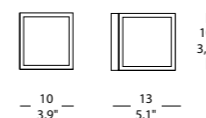
**DICE PP 10 LED**

9,3W 975Lm 3000K Cri>80 220-240V

9,3W 940Lm 2700K Cri>80 220-240V

CE IP40 3

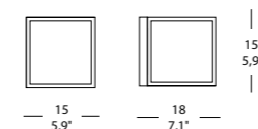
**DICE PP 15 LED**

13,9W 1320Lm 3000K Cri>80 220-240V

13,9W 1270Lm 2700K Cri>80 220-240V

CE IP40 3

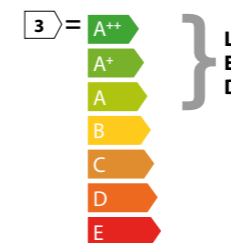
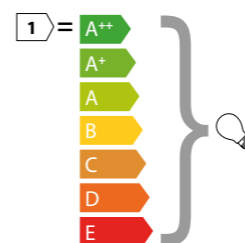

Un piccolo cubo di luce e creatività, originale nella forma e nella tecnica di produzione.

Le singole facce del cubo, bisellate con taglio a 45°, sono incollate con una tecnica ai raggi UV, che esalta lo spessore e la trasparenza del vetro extrachiaro, serigrafato internamente di colore bianco. Un effetto ricercato per mettere in evidenza la preziosità del cristallo e degli spigoli vivi.

Il risultato è un piccolo capolavoro di artigianato, la cui grandezza è proprio nei dettagli. Disponibile anche a LED.

Struttura: metallo nichel satinato e alluminio anodizzato.

Diffusore: vetro extrachiaro lucido con serigrafia bianca.

A small cube of light and creativity, with an original form and created using an original technique. The single faces of the cube are glued through a UV-technique, with a bevel of 45°, which enhances the thickness and transparency of the extra clear glass, which is white silk screen printed inside. A desired effect to highlight the preciousness of the crystal and sharp edges.

The result is a masterpiece of craftsmanship, whose greatness is in details. Available also with LED.

Frame: satin nickel - anodized aluminum metal.

Diffuser: extra- clear glass with polished white silkscreen.

Un petit cube de lumière et de créativité, original au niveau de la forme de la technique de production. Les seules faces du cube, biseautées avec une coupe à 45°, sont collées moyennant une technique aux rayons UV, qui exalte l'épaisseur et la transparence du verre extra clair, sérigraphié en blanc à l'intérieur. Un effet recherché pour mettre en évidence la préciosité du cristal et des arêtes vives. Le résultat est un petit chef-d'œuvre d'artisanat, dont la grandeur est justement dans les détails. Egalement disponible dans la version à LED.

Structure: métal nickel satiné et aluminium anodisé.

Diffuseur: verre extra clair brillant avec sérigraphie blanche.

DICE**technical detailed lists**

design **andrea lazzari**

Un pequeño cubo de luz y creatividad, original en la forma y en la técnica de producción.

Cada una de las caras individuales del cubo, biseladas con corte a 45°, están pegadas con una técnica de rayos UV, que exalta el espesor y la transparencia del vidrio extra claro, serigrafado de color blanco por el interior.

Un efecto rebuscado para resaltar la precisión del cristal y los cantos vivos. El resultado es una pequeña obra maestra de artesanía, cuya grandezza está en los detalles.

Disponible también en versión LED

Estructura: metal níquel satinado y aluminio anodizado.

Diffusor: vidrio extra claro brillante con serigrafía blanca.

Ein kleiner aus Licht und Kreativität bestehender Würfel, originell in seiner Form und Herstellungstechnik.

Die einzelnen Würfelseiten, die auf 45° abgeschrägt sind, wurden mit einer UV-Strahlentechnik verklebt und heben die Stärke und Transparenz des extrahellen, intern weiß siebgedruckten Glases hervor. Ein gewünschter Effekt, um die Kostbarkeit des Kristalls und der Kanten hervorzuheben. Das Ergebnis ist ein kleines Meisterstück des Handwerks, dessen Größe in den Details liegt. Erhältlich auch in der Version mit LED.

Struktur: Metall nickelsatiniert und Alu-eloxiert.

Diffuser: Glänzendes, extrahelles Glas mit weißem Siebdruck.

Маленький куб света и креативности, характеризующийся оригинальной формой и техникой исполнения. Грани куба, скошенные под углом 45°, склеены по технике склеивания стекла с УФ отверждением, подчеркивающей толщину и абсолютную прозрачность стекла. Белый цвет внутренней части стекла получен с помощью шелкографии.

Изысканный эффект позволяет подчеркнуть ценность хрустя и его острых граней.

Результат - маленький шедевр ремесла, заключающего в своих деталях величие. Выпускается также и в версии LED.

Структура: металл сатиновый никель и анодированный алюминий

Рассеиватель: сверхпрозрачное прозрачное блестящее стекло с белой шелкографией

vintage



EVISTYLE

DESIGN STEFANO MANDRUZZATO



VINTAGE GLASS SO 2_BAROCCO

EVISTYLE



DESIGN STEFANO MANDRUZZATO

VINTAGE GLASS SO 5_PAGODA

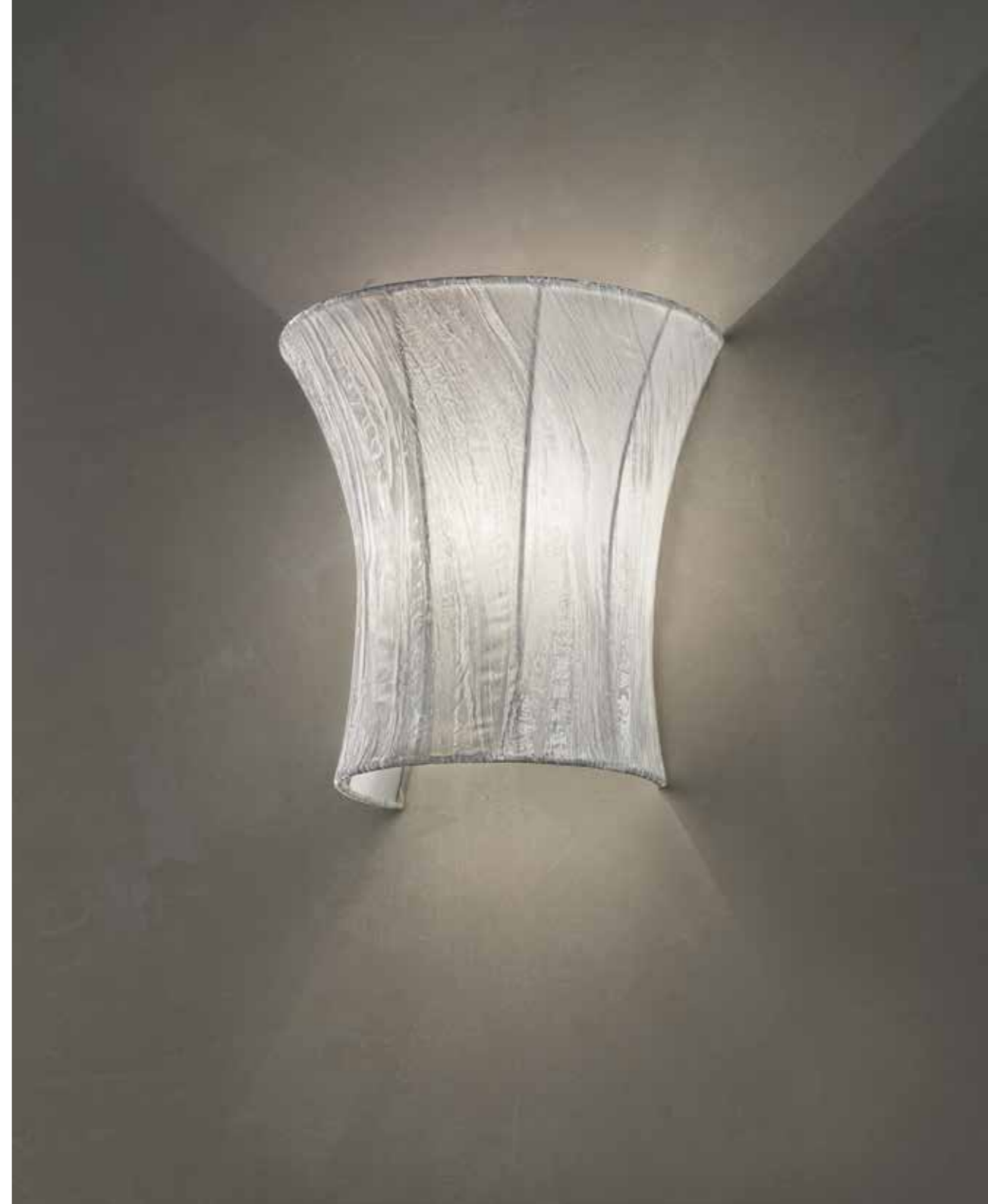



VINTAGE SO5 - versione speciale/special version

EVISTYLE



DESIGN STEFANO MANDRUZZATO

VINTAGE SO 1_PAGODA





VINTAGE PA_PAGODA

EVISTYLE



DESIGN STEFANO MANDRUZZATO

VINTAGE SO 60_PAGODA



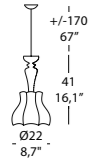
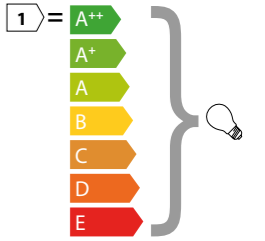

VINTAGE GLASS SO 1 PAGODA

1 x MAX 53W E27 aloe. ENERGY SAVER
 o/or
 1 x MAX 20W E27 PL-EL ENERGY SAVING

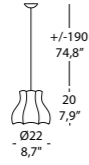

VINTAGE SO 1 PAGODA

1 x MAX 53W E27 aloe. ENERGY SAVER
 o/or
 1 x MAX 20W E27 PL-EL ENERGY SAVING

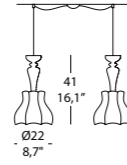

VINTAGE GLASS SO 2 PAGODA

2 x MAX 53W E27 aloe. ENERGY SAVER
 o/or
 2 x MAX 20W E27 PL-EL ENERGY SAVING

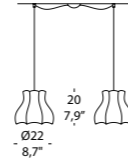

VINTAGE SO 2 PAGODA

2 x MAX 53W E27 aloe. ENERGY SAVER
 o/or
 2 x MAX 20W E27 PL-EL ENERGY SAVING

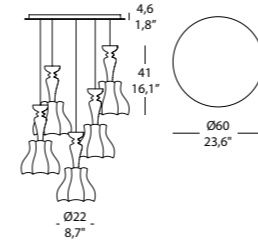

VINTAGE GLASS SO 5 PAGODA

5 x MAX 53W E27 aloe. ENERGY SAVER
 o/or
 5 x MAX 20W E27 PL-EL ENERGY SAVING

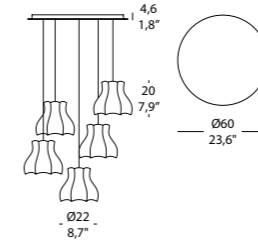

VINTAGE SO 5 PAGODA

5 x MAX 53W E27 aloe. ENERGY SAVER
 o/or
 5 x MAX 20W E27 PL-EL ENERGY SAVING

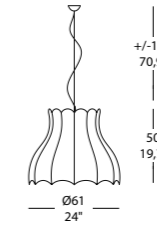

VINTAGE SO 60 PAGODA

1 x MAX 105W E27 aloe. ENERGY SAVER
 o/or
 1 x MAX 23W E27 PL-EL ENERGY SAVING

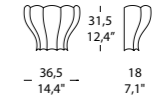

VINTAGE PA PAGODA

1 x MAX 70W E27 aloe. ENERGY SAVER
 o/or
 1 x MAX 23W E27 PL-EL ENERGY SAVING

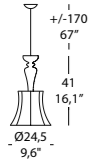

VINTAGE GLASS SO 1 CAMPANA

1 x MAX 53W E27 aloe. ENERGY SAVER
 o/or
 1 x MAX 20W E27 PL-EL ENERGY SAVING

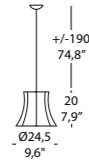

VINTAGE SO 1 CAMPANA

1 x MAX 53W E27 aloe. ENERGY SAVER
 o/or
 1 x MAX 20W E27 PL-EL ENERGY SAVING

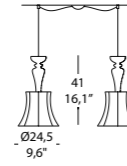

VINTAGE GLASS SO 2 CAMPANA

2 x MAX 53W E27 aloe. ENERGY SAVER
 o/or
 2 x MAX 20W E27 PL-EL ENERGY SAVING

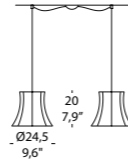

VINTAGE SO 2 CAMPANA

2 x MAX 53W E27 aloe. ENERGY SAVER
 o/or
 2 x MAX 20W E27 PL-EL ENERGY SAVING

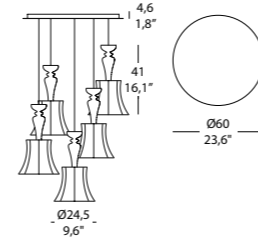

VINTAGE GLASS SO 5 CAMPANA

5 x MAX 53W E27 aloe. ENERGY SAVER
 o/or
 5 x MAX 20W E27 PL-EL ENERGY SAVING

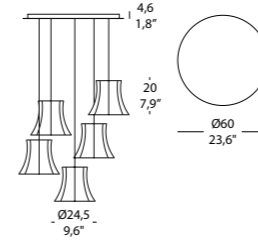

VINTAGE SO 5 CAMPANA

5 x MAX 53W E27 aloe. ENERGY SAVER
 o/or
 5 x MAX 20W E27 PL-EL ENERGY SAVING

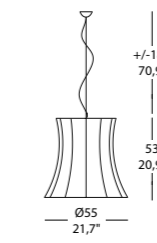

VINTAGE SO 55 CAMPANA

1 x MAX 105W E27 aloe. ENERGY SAVER
 o/or
 1 x MAX 23W E27 PL-EL ENERGY SAVING

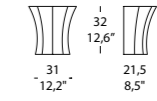

VINTAGE PA CAMPANA

1 x MAX 70W E27 aloe. ENERGY SAVER
 o/or
 1 x MAX 23W E27 PL-EL ENERGY SAVING

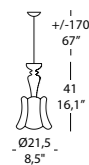

VINTAGE GLASS SO 1 BAROCCO

1 x MAX 53W E27 aloe. ENERGY SAVER
 o/or
 1 x MAX 20W E27 PL-EL ENERGY SAVING

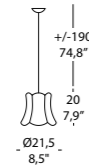

VINTAGE SO 1 BAROCCO

1 x MAX 53W E27 aloe. ENERGY SAVER
 o/or
 1 x MAX 20W E27 PL-EL ENERGY SAVING

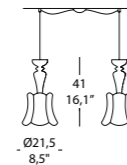

VINTAGE GLASS SO 2 BAROCCO

2 x MAX 53W E27 aloe. ENERGY SAVER
 o/or
 2 x MAX 20W E27 PL-EL ENERGY SAVING

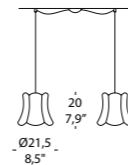

VINTAGE SO 2 BAROCCO

2 x MAX 53W E27 aloe. ENERGY SAVER
 o/or
 2 x MAX 20W E27 PL-EL ENERGY SAVING

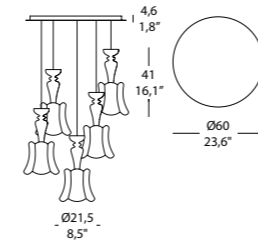

VINTAGE GLASS SO 5 BAROCCO

5 x MAX 53W E27 aloe. ENERGY SAVER
 o/or
 5 x MAX 20W E27 PL-EL ENERGY SAVING

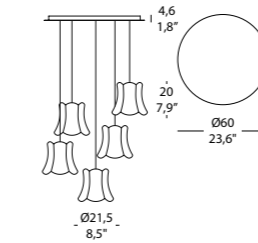

VINTAGE SO 5 BAROCCO

5 x MAX 53W E27 aloe. ENERGY SAVER
 o/or
 5 x MAX 20W E27 PL-EL ENERGY SAVING

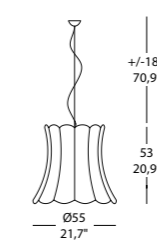

VINTAGE SO 55 BAROCCO

1 x MAX 105W E27 aloe. ENERGY SAVER
 o/or
 1 x MAX 23W E27 PL-EL ENERGY SAVING

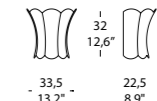

VINTAGE PA BAROCCO

1 x MAX 70W E27 aloe. ENERGY SAVER
 o/or
 1 x MAX 23W E27 PL-EL ENERGY SAVING

CAMPIONI COLORE/SAMPLES COLORS



AQ: Acquamare/Aquamarine



GL: Glicine/Wisteria



AV: Avorio/Ivory



SR: Rosso sultano/Sultan red



NE: Nero/Black



OR: Oro/Gold



CC: Crema caffè/Coffee cream

Una collezione di lampade di ispirazione d'antan dall'eleganza attuale e dall'essenza innovativa. I paralumi, in tre forme dall'inconfondibile richiamo vintage, sono rivestiti con un esclusivo velluto stropicciato, che ne rinnova lo stile e arricchisce la lampada di un prezioso effetto cangiante, che li rende unici. Disponibile in eleganti colorazioni e in diverse versioni a sospensione e da parete, Vintage si accosta in maniera raffinata all'arredamento classico, creando al contrario brillanti contrasti con l'arredo più moderno.

La variante a sospensione piccola viene impreziosita da un elemento in vetro soffiato con la tipica lavorazione Muranese del "rigadin".

Current elegance and innovative essence: a collection of lamps inspired by a d'antan style. The exclusive crumpled velvet, with which the three vintage lampshades are coated, renews the style and enriches the lamp of a precious iridescent effect, which makes the shade unique.

Available in stylish colors and in different pendant and wall versions, Vintage adapts elegantly to the classic furnishing, creating, on the contrary, brilliant contrasts with the more modern furniture. The version with the small pendant lamp is enhanced by an element in blown glass created through the typical Murano processing technique "rigadin".

Struttura: metallo cromato.
Diffusore: paralume in velluto stropicciato nei colori avorio, nero, rosso sultano, crema caffè, glicine, acquamarina e oro.

Frame: chromed metal.
Diffuser: shade in crumpled velvet in: ivory, black, sultan-red, coffee-cream, wisteria, aquamarine and gold.

Une collection de lampes d'antan d'une élégance actuelle et à l'essence innovante. Les abat-jours, aux trois formes rappelant le vintage de façon remarquable, sont revêtus d'un velours froissé exclusif, qui en renouvelle le style et enrichit la lampe d'un effet chatoyant précieux qui en fait des objets uniques. Fournie dans d'élégantes couleurs et dans différentes versions à suspension et murales, Vintage peut-être assortie avec raffinement à un ameublement classique, en créant des contrastes brillants avec la

décoration plus moderne. La variante à petite suspension est enrichie d'un élément en verre soufflé suivant la méthode de travail typique de Murano appelée le "rigadin".

Structure: métal chromé
Diffuseur: abat-jour en velours froissé dans les teintes ivoire, noir, rouge sultan, crème café, glicine, aigue-marine et or.

Eine Lampenkollektion nach historischer Inspiration, mit aktueller Eleganz und innovativer Essenz. Die Lampenschirme mit ihren 3 unverwechselbaren Vintage-Formen sind mit einem exklusiven und zerknitterten Samtstoff verkleidet. Dieser erneuert ihren Stil und bereichert die Lampe mit einem edlen und irisierenden Effekt. Das macht sie einzigartig. Sie ist erhältlich in eleganten Farben und diversen Versionen mit Abhängung und für die Wandapplikation. Vintage integriert sich in edler Art und Weise in die klassische Einrichtung und erzeugt im Gegensatz brillante Kontraste mit der modernen Einrichtung.

Die Ausführung mit kleiner Abhängung wird durch ein Element in geblasenem "Rigadin"-Glas mit der typischen "Murano"-Verarbeitung aufgewertet.

Struktur: Metall verchromt.
Diffusor: Lampenschirm mit zerknittertem Samtstoff in den Farben: Elfenbein, Schwarz, Sultan Rot, Kaffeesahne, Glyzinie, Aquamarin und Gold.

Una colección de lámparas de inspiración de antaño, de elegancia actual y de esencia innovadora. Las pantallas en tres formas de inconfundible evocación de antaño están forradas con un terciopelo arrugado y exclusivo que renueva el estilo y enriquece la lámpara con un preciso efecto cambiante haciéndolas únicas. Disponible en elegantes colores y en varias versiones, de suspensión y de pared, Vintage se combina en modo refinado con la decoración clásica creando al contrario brillantes contrastes con el mobiliario más moderno. La variante de suspensión pequeña es valorizada por un elemento de vidrio soplado con el típico trabajo de Murano del "rigadin".

Estructura: metal cromado
Difusor: pantalla de terciopelo arrugado en los colores marfil, negro, rojo sultán, crema de café, glicina, aguamarina y oro.

VINTAGE

technical detailed lists

design stefano mandruzzato

Коллекция светильников, созданная под вдохновением прошлого, из актуальной элегантностью и инновационной сущностью. Уникальный велюр с эффектом жатости, из которого выполнены три винтажных абажура, обновляет стиль и придает светильнику эффект «шанжан», делая его уникальными.

Коллекция предоставляется в элегантных расцветках и различных версиях: подвесной и настенной, Vintage приближается в утонченной манере к классической обстановке, создавая, наоборот, превосходный контраст с самой современной обстановкой.

Маленький подвесной светильник украшен элементом из типичного дутого муранского стекла "rigadin".

Структура: Хромированный металл
Рассеиватель: Абажур из велюра с эффектом жатости предоставляется в следующих вариантах цвета: слоновая кость, черный, темно-красный, кремовый, глициниевый, цвет морской волны и золотой.

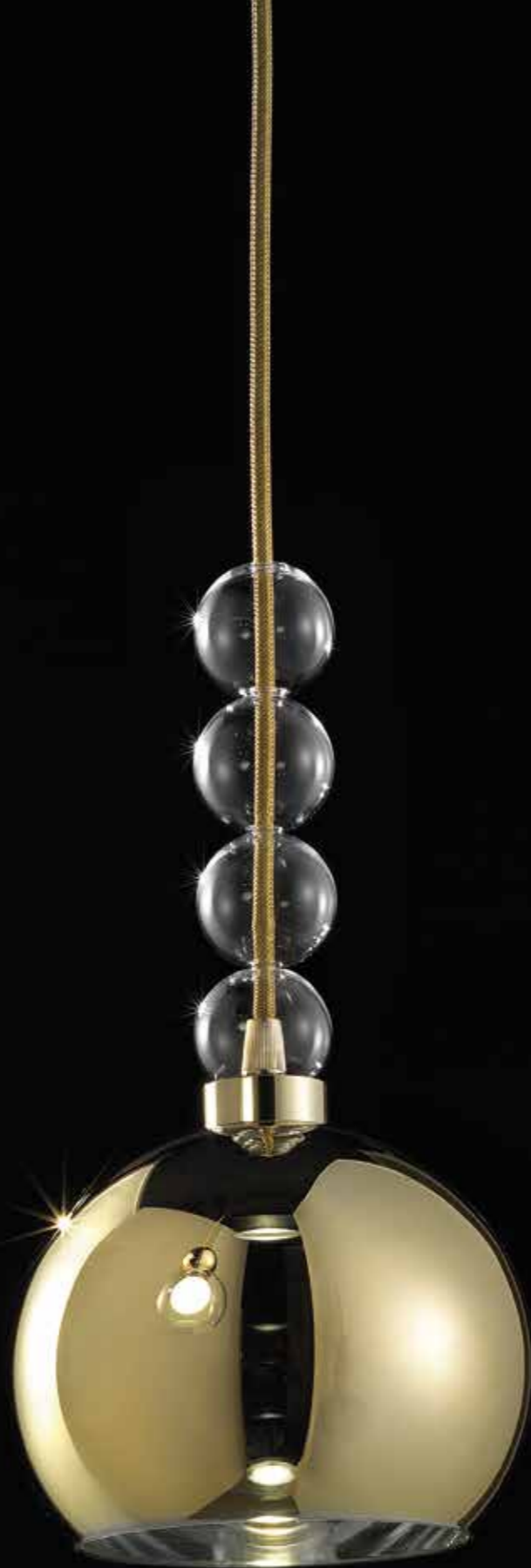

EVI STYLE

DESIGN DIMA LOGINOFF



EVI STYLE



DESIGN DIMA LOGINOFF



EVI STYLE



DESIGN DIMA LOGINOFF



EVI STYLE



DESIGN DIMA LOGINOFF



78/79

EVI STYLE

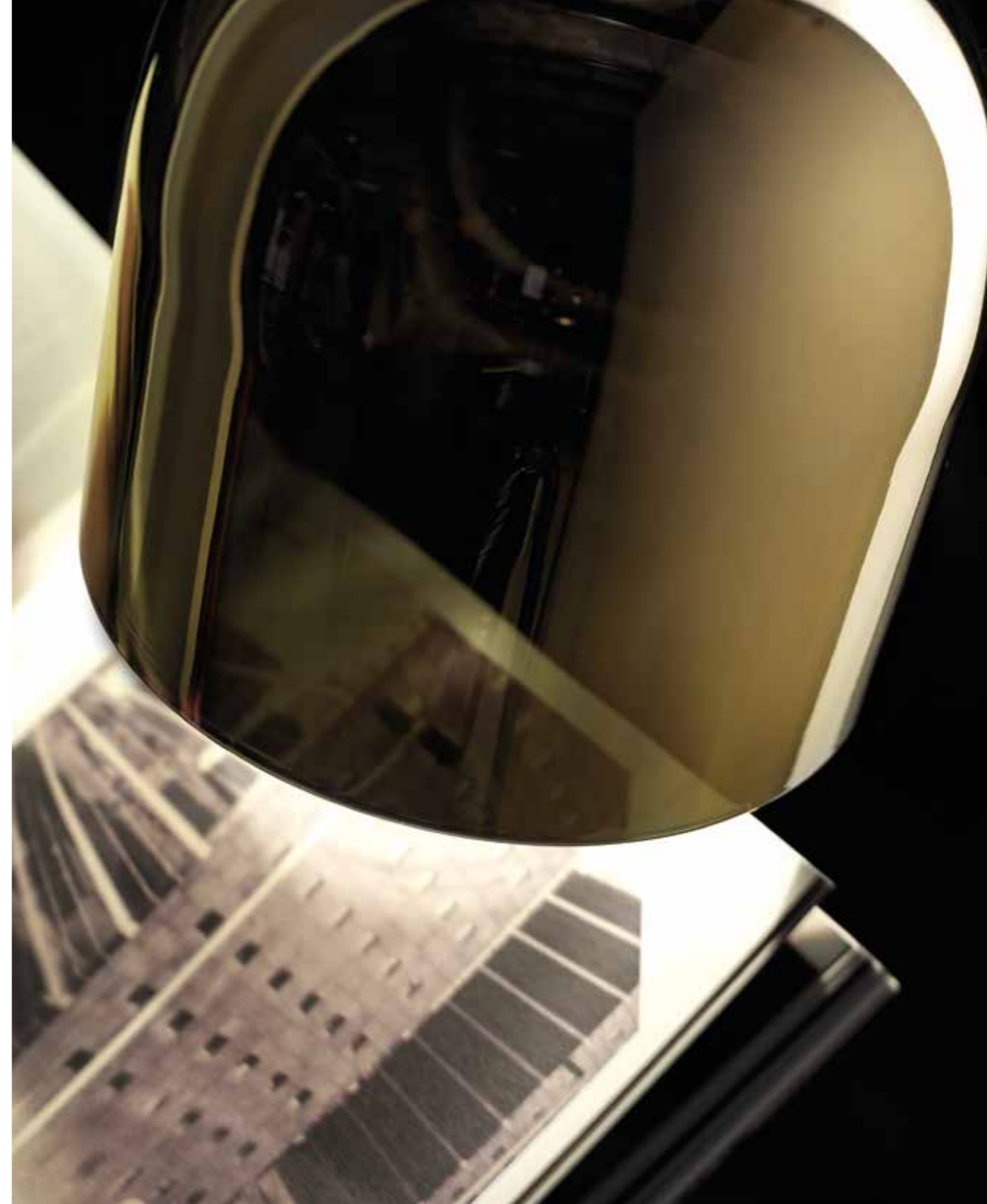

DESIGN DIMA LOGINOFF



Varianti vetro/Glass Versions

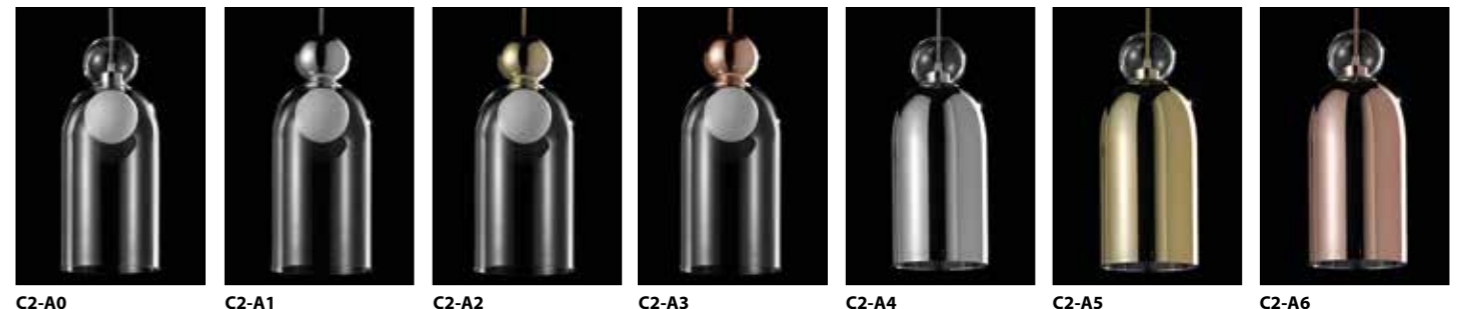

Dettagli/Details

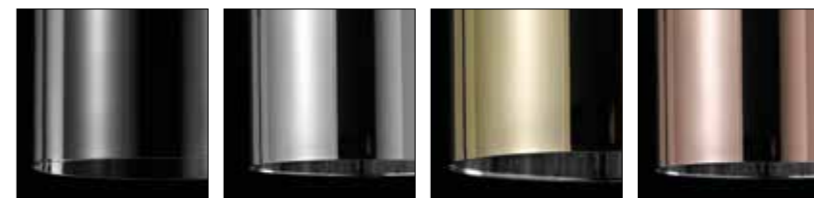

Trasparente
Transparent

Cromo
Chrome

Oro
Gold

Rame
Copper

SOSPENSIONI (CAVO STANDARD CM 200)/PENDANT LAMPS (STANDARD CABLE CM 200)

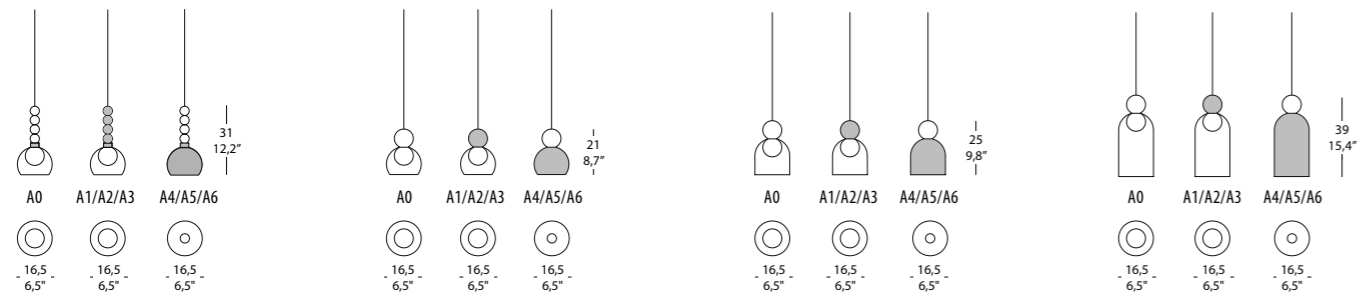

MEMORIA S1

4,6W 440 Lm 3000K Cri>80 500 mA LED



MEMORIA S2

4,6W 440 Lm 3000K Cri>80 500 mA LED



MEMORIA C1

4,6W 440 Lm 3000K Cri>80 500 mA LED



MEMORIA C2

4,6W 440 Lm 3000K Cri>80 500 mA LED

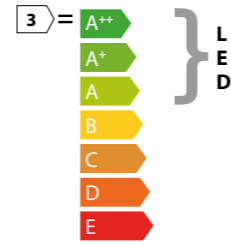

ROSONI/CANOPIES

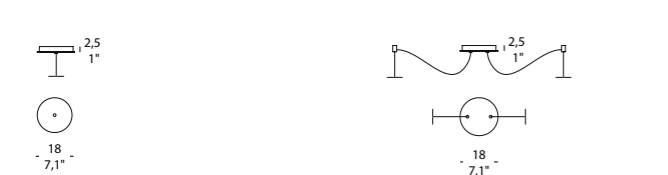

MEMORIA RO-1

ROSONE A 1 LUCE CON DRIVER 220-240V
1-LIGHT CANOPY WITH DRIVER 220-240V



MEMORIA RO-2

ROSONE A 2 LUCI CON DRIVER 220-240V
2-LIGHT CANOPY WITH DRIVER 220-240V

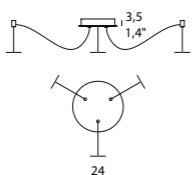

MEMORIA RO-3

ROSONE A 3 LUCI CON DRIVER 220-240V
3-LIGHT CANOPY WITH DRIVER 220-240V

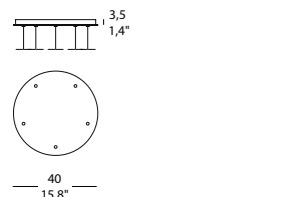

MEMORIA RO-5

ROSONE A 5 LUCI CON DRIVER 220-240V
5-LIGHT CANOPY WITH DRIVER 220-240V

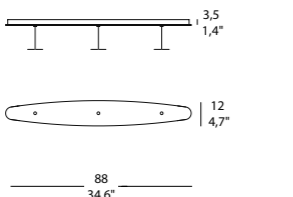

MEMORIA BI-3

BINARIO A 3 LUCI CON DRIVER 220-240V
3-LIGHT TRACK WITH DRIVER 220-240V

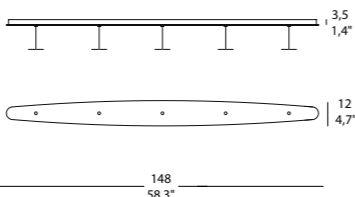

MEMORIA BI-5

BINARIO A 5 LUCI CON DRIVER 220-240V
5-LIGHT TRACK WITH DRIVER 220-240V



ESEMPI DI COMPOSIZIONE/ EXAMPLES OF COMPOSITION

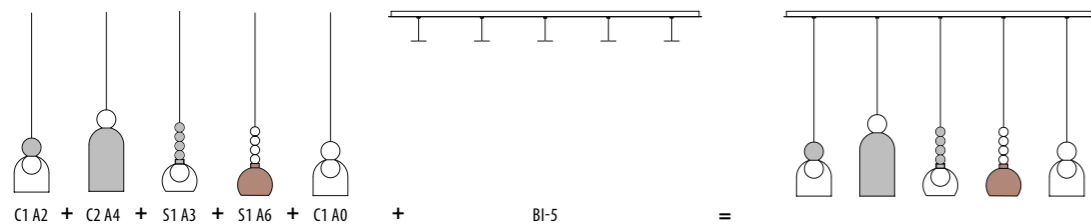
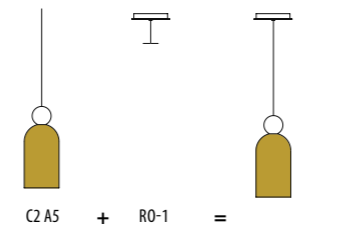
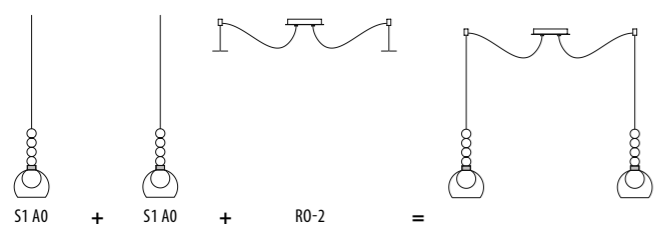

Stile internazionale e ricercatezza italiana, per una collezione di lampade a sospensione che rimanda all'estetica dell'Art Déco, rivisitata in chiave più moderna e chic.

Disponibile in versione singola o multipla, sia circolare che lineare, Memoria può acquisire ulteriore esclusività giocando con i volumi dei suoi elementi e le diverse tonalità dei diffusori in vetro: trasparenti o metallizzati in oro, cromo e rame, abbinati a cavi rivestiti in calza metallica dello stesso colore. L'effetto ottenuto con i diffusori metallizzati, definito "trans-mirror", esalta il fascino della lampada generando a luce accesa sofisticate trasparenze. La versione con diffusore trasparente invece, racchiude al suo interno una luminosa sfera in vetro soffiato, testimone della cura del dettaglio tipica del brand.

Tutta la collezione utilizza sorgenti a LED.

Struttura: metallo bianco opaco, con particolari in cromo, oro e rame.
Diffusore: vetro trasparente, cromo, oro e rame, in diverse combinazioni.

With a reference to Art Decò, revisited in a more modern and chic key, this collection of pendant lamps is the representation of International style and Italian preciousness. Available in single and multiple, as well as in circular and linear versions, Memoria can gain additional exclusivity playing with the volumes of its elements and the different shades of glass diffusers: transparent or metalized in gold, chrome and copper, combined with cables of the same color, coated with metal braid. The "trans-mirror" effect, obtained with the metalized diffusers, enhances the charm of the lamp creating sophisticated transparencies when the light is on. The version with the transparent diffuser, instead, contains within it a bright ball in blown glass, a witness of the attention to detail, that is a typical element of the brand. The entire collection uses LED sources.

Frame: matt white metal, with details in chrome, gold and copper
Diffuser: glass in transparent, chrome, gold and copper, in various combinations.

Style international et raffinement italien, pour une collection de lampes à suspension qui renvoie à l'esthétique de l'Art Déco, revue sous un jour plus moderne et chic.

différentes tonalités des diffuseurs en verre : transparents ou métallisés en or, chrome et cuivre, associés à des câbles revêtus d'une gaine métallique de la même couleur. L'effet obtenu avec les diffuseurs métallisés, défini "trans-mirror", exalte le charme de la lampe en générant des transparences sophistiquées lorsqu'elle est allumée.

En revanche, la version avec un diffuseur transparent, contient une sphère lumineuse en verre soufflé, témoignant du soin du détail typique de la marque. Toute la collection utilise des sources à LED.

Structure: métal blanc opaque, avec des détails en chrome, or et cuivre.
Diffuseur: verre transparent, chrome, or et cuivre, dans différentes combinaisons.

Estilo internacional y elegancia italiana para una colección de lámparas de suspensión que recuerda la estética del Art Déco revisitada en clave más moderna y chic.

Disponibile in versione singola o multipla, tanto circular como lineal, Memoria puede adquirir más exclusividad jugando con los volúmenes de sus elementos y los varios tonos de los difusores en vidrio: transparentes o metalizados en oro, cromo y cobre, combinados con cables forrados en trenza metálica del mismo color.

El efecto obtenido con los difusores metalizados, definido "trans-mirror", exalta el encanto de la lámpara generando sofisticadas transparencias con la luz encendida. La versión con difusor transparente en cambio, encierra en su interior una luminosa esfera de vidrio soplado, testigo del cuidadoso detalle, típico de la marca. Toda la colección utiliza fuentes de LED.

Estructura: metal blanco opaco, con detalles de cromo, oro y cobre.
Difusor: vidrio transparente, cromo oro y cobre, en varias combinaciones.

Internationaler Stil und italienische Raffinesse für eine Lampenkollektion mit Abhängung, die sich an die Ästhetik des Art Deco in moderner und eleganter Form anlehnt. Sie ist erhältlich in einfacher oder mehrfacher Version, sowohl kreisförmig als auch linear. Memoria gewinnt zusätzliche Exklusivität durch das Spiel mit dem Volumen seiner Elemente und den unterschiedlichen Tonalitäten (transparent oder metallisiert) in Gold, verchromt und Kupfer) der Glas-Lampenschirme im Einklang mit den umkleideten Kabeln in der gleichen

MEMORIA

technical detailed lists

design dima loginoff

Farbe. Der sogenannte "Spiegel-Effekt" der durch die metallisierten Diffusoren erzielt wird, erhöht den Charme der Lampe die bei eingeschaltetem Licht anspruchsvolle Transparenz erzeugt. Die Ausführung mit transparentem Diffusor hingegen, umschließt im Inneren eine helle Kugel in geblasenem Glas. Der Beweis für die Liebe zum Detail, typisch für unsere Marke. Die ganze Kollektion ist exklusiv mit LED-Lichtquellen ausgestattet.

Struktur: Metall mattweiß, Details in Chrom, Gold und Kupfer.
Diffusor: Glas transparent, Chrom, Gold und Kupfer, verschiedene Kombinationen möglich.

Интернациональный стиль и итальянская изысканность, для роскошной коллекции подвесных светильников, которая возвращает к эстетике стиля ар-деко, переосмысленной в современном ключе.

Предоставлена в виде одиночного светильника или группы светильников, как с линейным, так и с круговым расположением, Memoria может приобрести дополнительную исключительность, играя с объемами своих элементов и разными оттенками своих рассеивателей из стекла: прозрачных или металлизированных, доступных в следующих цветах: золото, хром и медь; с проводами, в металлической оплетке такого же цвета.

Эффект, полученный с применением металлизированных рассеивателей, названный "trans-mirror", подчеркивает обаяние светильника, создавая во включенном состоянии изысканную прозрачность.

Версия с прозрачным рассеивателем, напротив, заключает внутри себя светящуюся сферу из дутого стекла - свидетеля заботы о деталях, типичной для бренда. Во всей коллекции в качестве источника света используется LED.

Структура: белый матовый металл с деталями, выполненными в следующих расцветках: хром, золото и медь. Рассеиватель из стекла: возможные расцветки: прозрачный, хром, золото и медь, в различных сочетаниях.



MOROSINI

t. +39 041 5952772
f. +39 041 5956175
info@morosinisrl.com
www.morosinisrl.com

EVI STYLE Passion for Light

t. +39.041.5951544
f. +39.041.5956175
info@evistyle.com
www.evistyle.com

Brands of **Luci Italiane** srl
via delle Industrie, 70
30020 Marcon (VE) - Italy